

注释:

1. 有效焦距: -200mm
2. 后焦距: -201.10mm
3. 净通光孔径: 38mm
4. 镀膜: $R_{avg} < 0.5\%$ @400-700nm

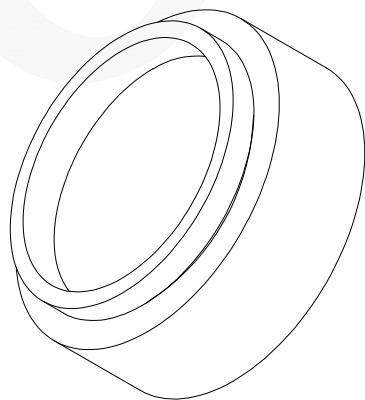
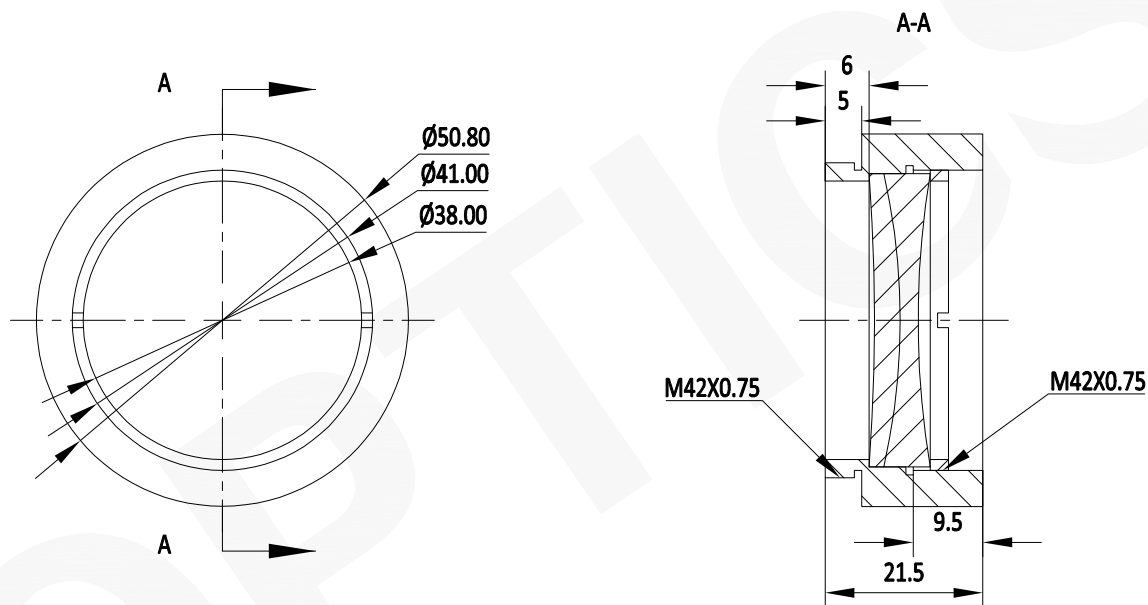

注:

- 1: 本图仅供参考, 禁止使用本图加工生产.
- 2: 图纸细节如有更改不再另行通知.

 **GU OPTICS**

联合光科技(北京)有限公司

名称	已装配负胶合消色差透镜 VIS镀膜 D=40mm F=-200mm			
产品编号	145260	单位	mm	